

Front/Side Installation Type

■ Features

- Easy front (M18 nut) and side (M3 bolt/nut) installation
- NPN open collector / PNP open collector simultaneous output
- Sensing distance: Through-beam type 20m / Retroreflective type 4m / Diffuse reflective type 1m, 300mm
- Small size: W14×H34.5×L28mm
- M.S.R. (Mirror Surface Rejection) function prevents malfunction from reflective objects such as metals or mirrors (retroreflective type)
- Sensitivity adjuster
- Light ON/Dark ON selectable by switch
- Operation indicator (red LED) and stability indicator (green LED)
- Power reverse polarity protection circuit, Output short over current protection circuit
- Interference prevention function (except through-beam type)
- IP67 protection structure (IEC standard)

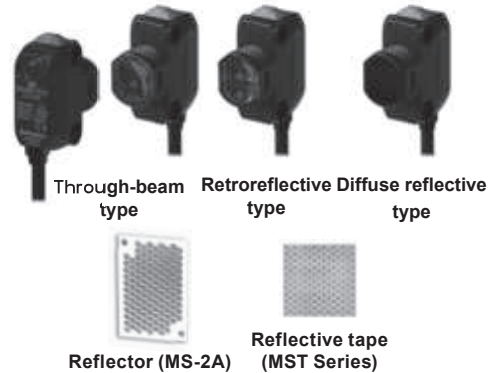

⚠ Please read "Safety Considerations" in operation manual before using.



■ Specifications

Model	BH20M-TDT	BH4M-PDT	BH1M-DDT	BH300-DDT
Sensing type	Through-beam	Retroreflective (built-in polarized filter)	Diffuse reflective	
Sensing distance	20m	4m ^{※1}	1m ^{※2}	300mm ^{※3}
Sensing target	Opaque material over Ø20mm	Opaque material over Ø75mm	—	
Hysteresis	—		Max. 20% at sensing distance	
Response time	Max. 1ms			
Power supply	12-24VDC [—] ±10% (ripple P-P: max. 10%)			
Current consumption	Emitter/Receiver : max. 20mA	Max. 30mA	Max. 35mA	Max. 30mA
Light source	Red LED (660nm)	Red LED (660nm)	Infrared LED (850nm)	Red LED (660nm)
Sensitivity adjustment	Sensitivity adjuster			
Operation mode	Light ON / Dark ON selectable by switch			
Control output	NPN / PNP open collector simultaneous 2 output · Load voltage: max. 26.4VDC [—] · Load current: max. 100mA · Residual voltage - NPN: max. 1VDC [—] , PNP: max. 2.5VDC			
Protection circuit	Interference prevention function (except through-beam type), power reverse polarity protection circuit, output short over current protection circuit			
Indicator	Operation indicator: red LED Stability indicator: green LED (emitter of through-beam type's power indicator: green)			
Connection	Cable type			
Insulation resistance	Over 20MΩ (at 500VDC megger)			
Dielectric strength	1,000VAC 50/60Hz for 1 minute			
Vibration	1.5mm amplitude at frequency of 10 to 55Hz (for 1 min) in each X, Y, Z direction for 2 hours			
Shock	500m/s ² (approx. 50G) in X, Y, Z direction for 3 times			
Environment	Ambient illu.	Sunlight: max. 11,000lx, incandescent lamp: max. 3,000lx (receiver illumination)		
	Ambient temp. ^{※4}	-25 to 55°C, storage: -40 to 70°C		
	Ambient humi.	35 to 85%RH, storage: 35 to 85%RH		
Protection structure	IP67 (IEC standard)			
Material	Case: polycarbonates, LED indicator: polycarbonates, sensing part: polymethyl methacrylate acrylic			
Cable	Ø4mm, 4-wire, 2.1m (emitter of through-beam type: Ø4mm, 2-wire, 2.1m) (AWG24, core diameter: 0.08mm, number of cores: 40, insulator out diameter: Ø1.03mm)			
Accessory	Common	Adjustment screwdriver, fixing bracket, M18 fixing nut, fixing cap, M3 bolt, M3 nut		
	Individual	—	Reflector (MS-2A)	—
Approval	CE cUL [—] US LISTED			
Weight ^{※5}	Approx. 190g (approx. 120g)	Approx. 140g (approx. 60g)	Approx. 130g (approx. 60g)	

※1: The sensing distance is specified with using the MS-2A reflector. The distance between the sensor and the reflector should be set over 0.1m. When using reflective tapes, the reflectivity will vary by the size of the tape. Please refer to the "■ Reflectivity By Reflective Tape Model" table before using the tape.

※2: Non-glossy white paper 300×300mm.

※3: Non-glossy white paper 100×100mm.

※4: UL approved surrounding air temperature 40°C

※5: The weight includes packaging. The weight in parenthesis is for unit only.

※ The temperature or humidity mentioned in Environment indicates a non freezing or condensation.

Front/Side Installation Type

■ Feature Data

◎ Through-beam type: BH20M-TDT

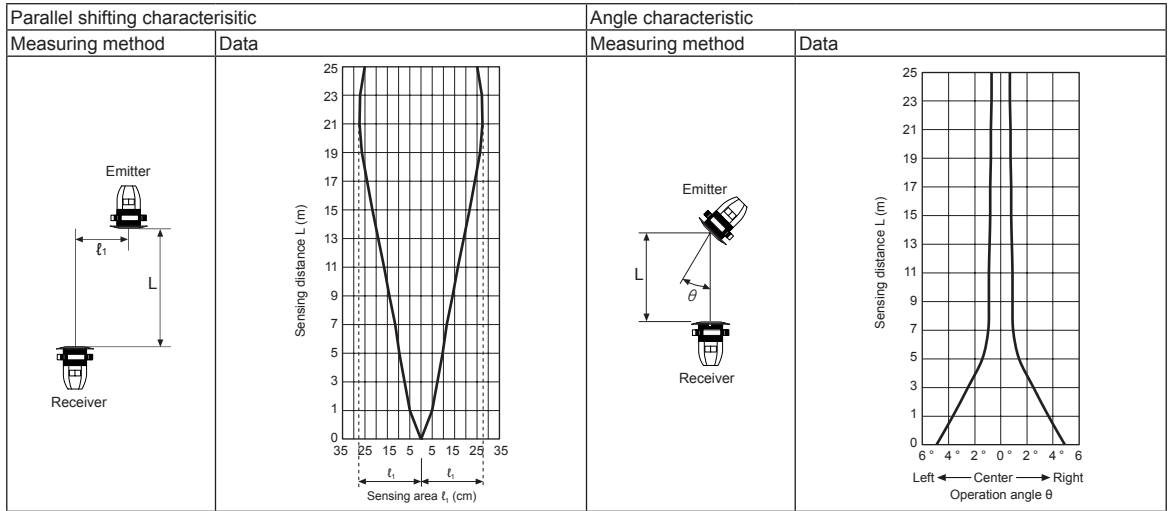

◎ Retroreflective type: BH4M-PDT

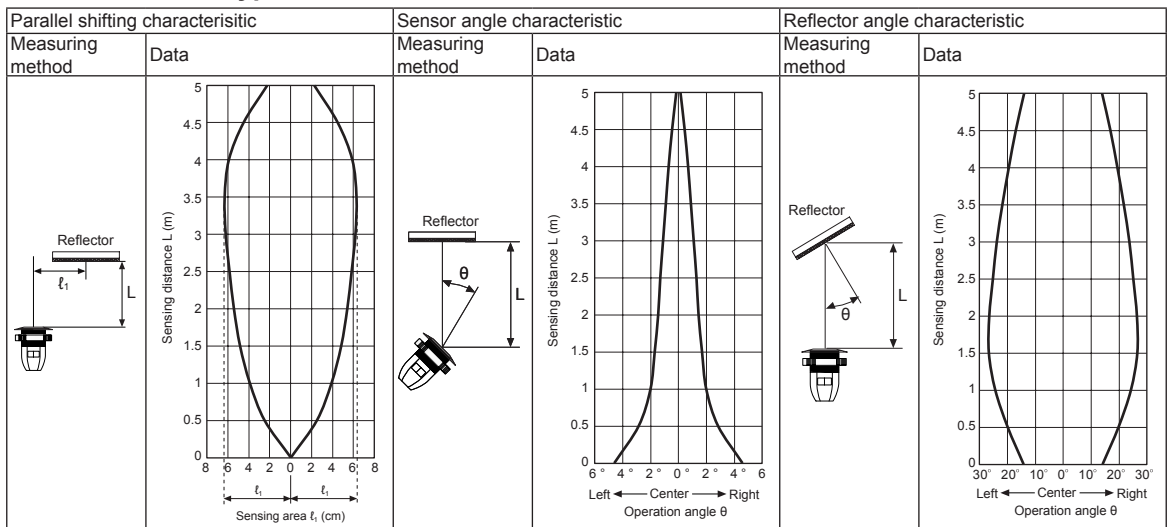

◎ Diffuse reflective type

• BH1M-DDT

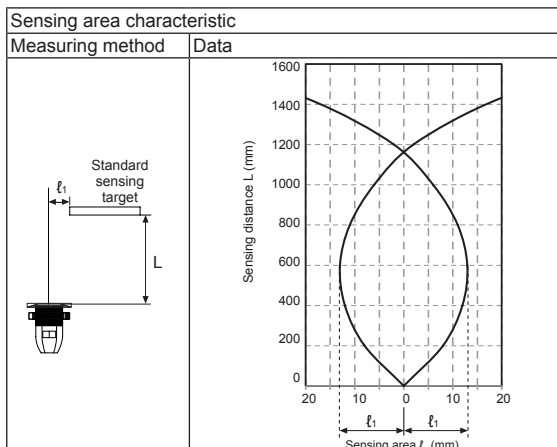

• BH300-DDT

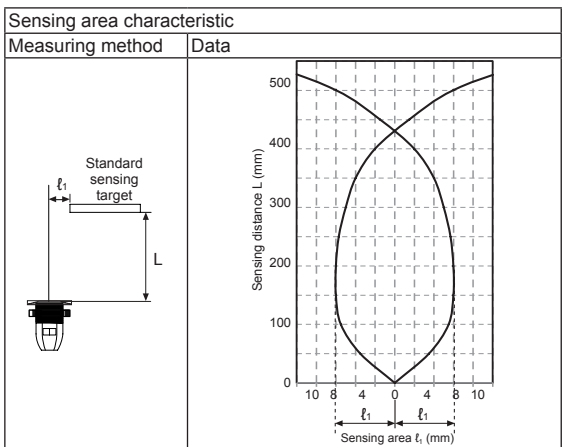

(A) Photoelectric Sensors

(B) Fiber Optic Sensors

(C) Door/Area Sensors

(D) Proximity Sensors

(E) Pressure Sensors

(F) Rotary Encoders

(G) Connectors/ Connector Cables/ Sensor Distribution Boxes/Sockets

(H) Temperature Controllers

(I) SSRs / Power Controllers

(J) Counters

(K) Timers

(L) Panel Meters

(M) Tacho / Speed / Pulse Meters

(N) Display Units

(O) Sensor Controllers

(P) Switching Mode Power Supplies

(Q) Stepper Motors & Drivers & Controllers

(R) Graphic/ Logic Panels

(S) Field Network Devices

(T) Software

BH Series

■ Connections

◎ Through-beam type

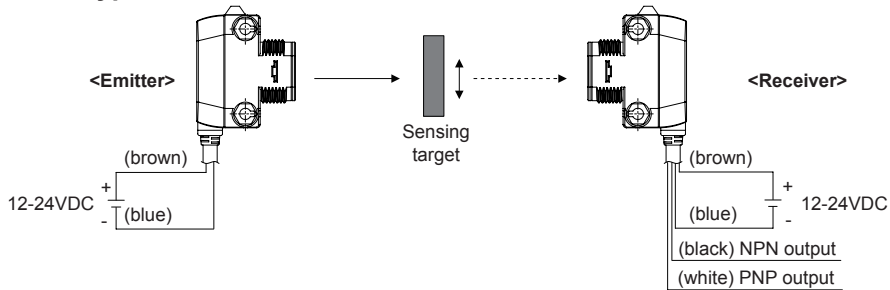

◎ Retroreflective type

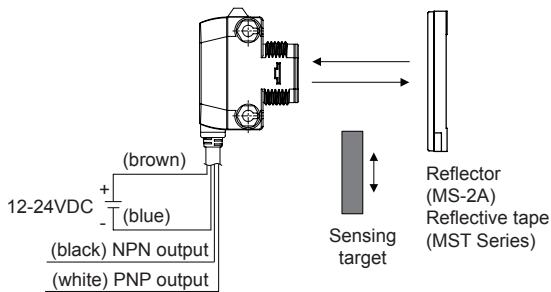

◎ Diffuse reflective type

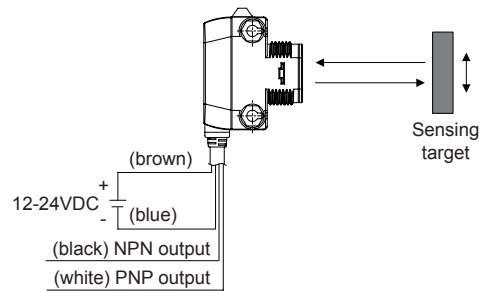

■ Control Output Diagram

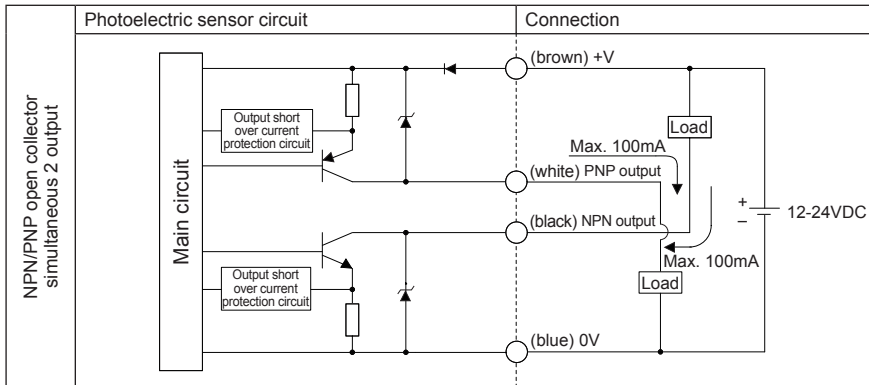

■ Operation Mode

Operation mode	Light ON	Dark ON
Receiver operation	Received light Interrupted light	Received light Interrupted light
Operation indicator (red LED)	ON OFF	ON OFF
Transistor output (NPN/PNP)	ON OFF	ON OFF

Front/Side Installation Type

■ Dimensions

(unit: mm)

◎ Through-beam type

<Emitter>

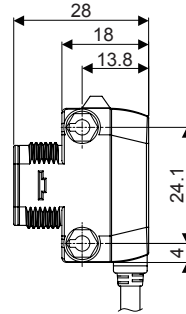
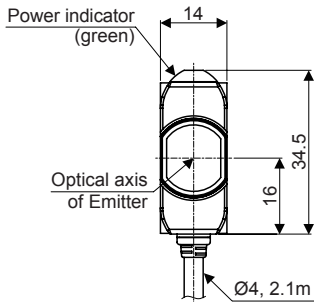

<Receiver>

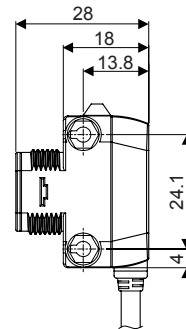
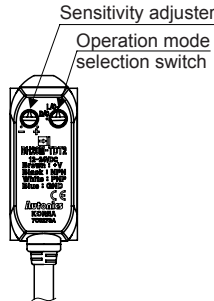
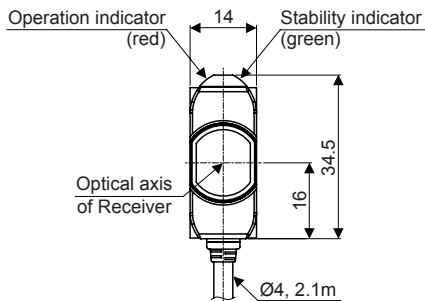

◎ Retroreflective type/Diffuse reflective type

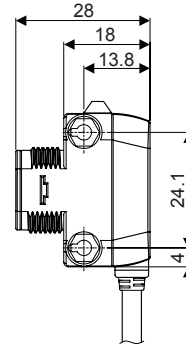
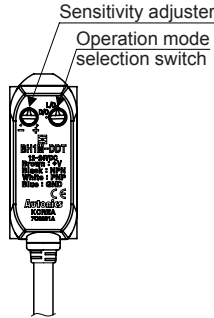
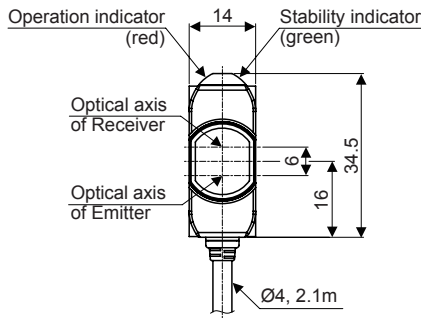

● Bracket

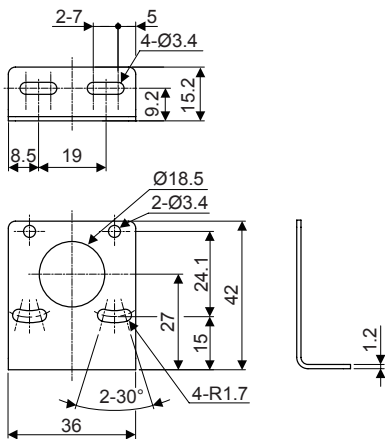

● M18 fixing nut

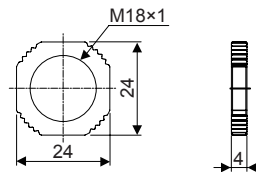

● Fixing cap

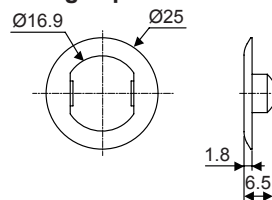

(A) Photoelectric Sensors

(B) Fiber Optic Sensors

(C) Door/Area Sensors

(D) Proximity Sensors

(E) Pressure Sensors

(F) Rotary Encoders

(G) Connectors/ Connector Cables/ Sensor Distribution Boxes/Sockets

(H) Temperature Controllers

(I) SSRs / Power Controllers

(J) Counters

(K) Timers

(L) Panel Meters

(M) Tacho / Speed / Pulse Meters

(N) Display Units

(O) Sensor Controllers

(P) Switching Mode Power Supplies

(Q) Stepper Motors & Drivers & Controllers

(R) Graphic/ Logic Panels

(S) Field Network Devices

(T) Software

BH Series

● Reflector (MS-2A)

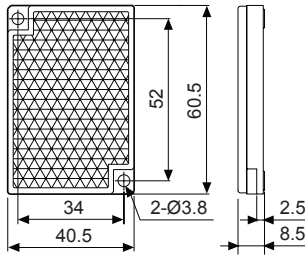

● Reflective tape (sold separately)

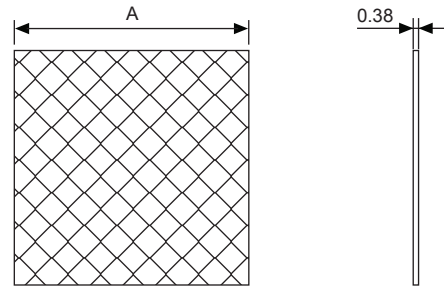

Model	A
MST-50-10	□ 50
MST-100-5	□ 100
MST-200-2	□ 200

■ Operation Timing Diagram

◎ Through-beam type

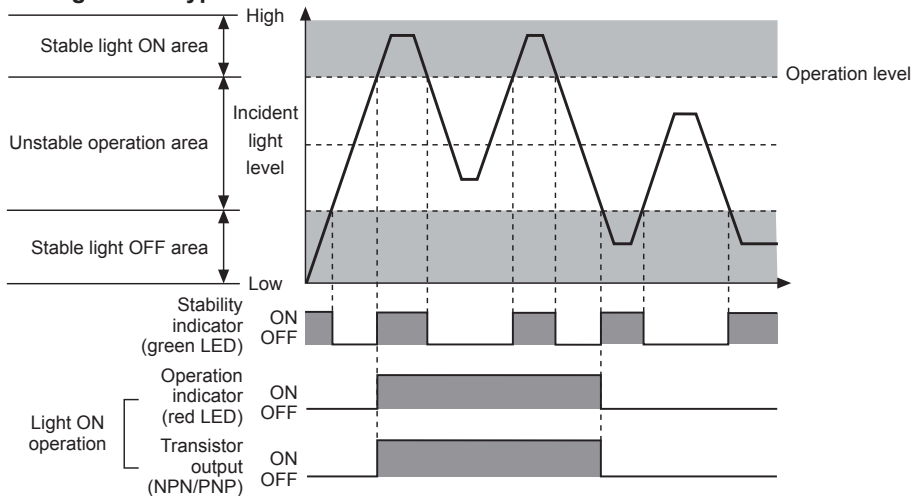

◎ Retroreflective type / Diffuse reflective type

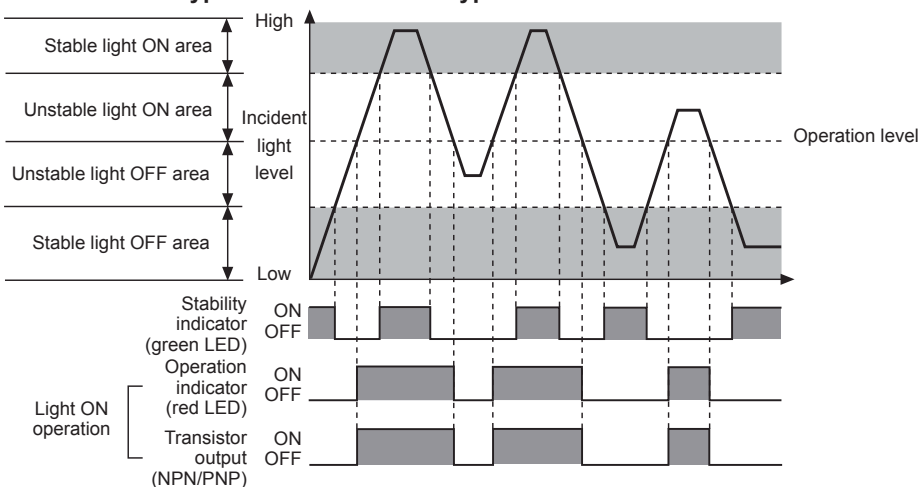

※The waveforms of "Operation indicator" and "Transistor output" are for Light ON, The waveforms are reversed for Dark ON.

Front/Side Installation Type

■ Installation and Sensitivity Adjustment

○ For mounting

Please use M18 fixing nut or M3 bolt and nut to mount the sensor, and make sure that the tightening torque is under 0.5N·m.
 ※Exercise caution. Do not apply excessive impact to the unit or bend the cable section. The inside unit may be wet.

<Front mounting>

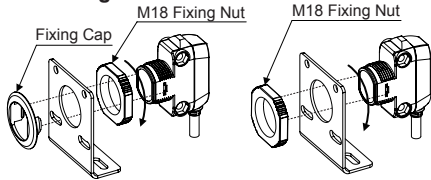

<Side mounting>

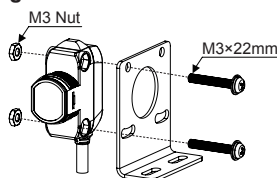

○ Optical axis adjustment

●Through-beam type

Set the emitter and the receiver facing each other and adjust these up-down, right-left after to check the point operating the stability indicator. Fix the emitter and the receiver at the center of the point.

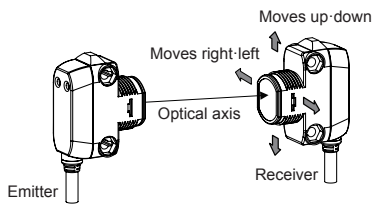

●Retroreflective type

Set the photoelectric sensor and the reflector(MS-2A) or reflective tape facing each other and adjust the reflector up-down, right-left after to check the point operating the stability indicator. Make sure that the sensing side of the sensor is parallel with the reflector.

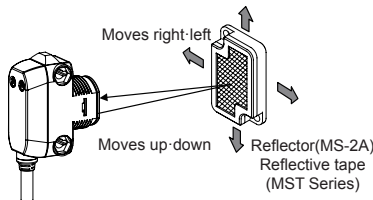

●Diffuse reflective type

After place a sensing target, fix it in the middle of position where the stability indicator operates adjusting the sensor to up-down, right-left. Make sure that the sensing side of the sensor is parallel with the surface of each sensing target.

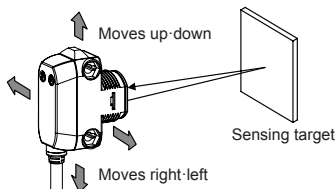

○ Operation mode switching

Light ON		Turn the operation mode selection switch to L/O direction (the end of right).
Dark ON		Turn the operation mode selection switch to D/O direction (the end of left).

※For through-beam type, the selection switch is built-in the receiver.

○ Sensitivity adjustment

Order	Sensitivity setting	Descriptions
1		From Light ON status, turn the sensitivity setting adjuster slowly to the right from min. sensitivity (-) and check the position where operation indicator turns on (A).
2		From Dark ON status, turn the sensitivity setting adjuster further right and check the position where the operation indicator turns on (B). Turn the adjuster left and check the position where the operation indicator turns off (C). ※If the operation indicator does not turn on at max. sensitivity (+), the maximum sensitivity setting is set at position (C).
3		Set the adjuster at the center position between (A) and (C) for optimal sensitivity. Also, check if the stability indicator turns off with or without the sensing target. If it does not turn off, please review the operation mode again, as sensitivity may be unstable.

	Light ON	Dark ON
Through-beam type		
Retro-reflective type		
Diffuse reflective type		

※Please set the sensitivity setting adjuster is executed in stable Light ON area and the reliability of environment (temperature, supply, dust etc.) is increased after the mounting it in a stable area.

※It may cause breakdown when the sensitivity setting adjuster or the operation mode selection switch is turned by force.

- (A) Photoelectric Sensors
- (B) Fiber Optic Sensors
- (C) Door/Area Sensors
- (D) Proximity Sensors
- (E) Pressure Sensors
- (F) Rotary Encoders
- (G) Connectors/ Connector Cables/ Sensor Distribution Boxes/Sockets
- (H) Temperature Controllers
- (I) SSRs / Power Controllers
- (J) Counters
- (K) Timers
- (L) Panel Meters
- (M) Tacho / Speed / Pulse Meters
- (N) Display Units
- (O) Sensor Controllers
- (P) Switching Mode Power Supplies
- (Q) Stepper Motors & Drivers & Controllers
- (R) Graphic/ Logic Panels
- (S) Field Network Devices
- (T) Software

BH Series

■ Reflectivity by Reflective Tape Model

MST-50-10 (50×50mm)	60%
MST-100-5 (100×100mm)	80%
MST-200-2 (200×200mm)	140%

- ※ This reflectivity is based on the reflector (MS-2A).
- ※ Reflectivity may vary depending on usage environment and installation conditions.
The sensing distance and minimum sensing target size increase as the size of the tape increases.
Please check the reflectivity before using reflective tapes.
- ※ For using reflective tape, installation distance should be min. 20mm.